

Polygonal Paper

Instructions

on gluing the lion's head out of paper

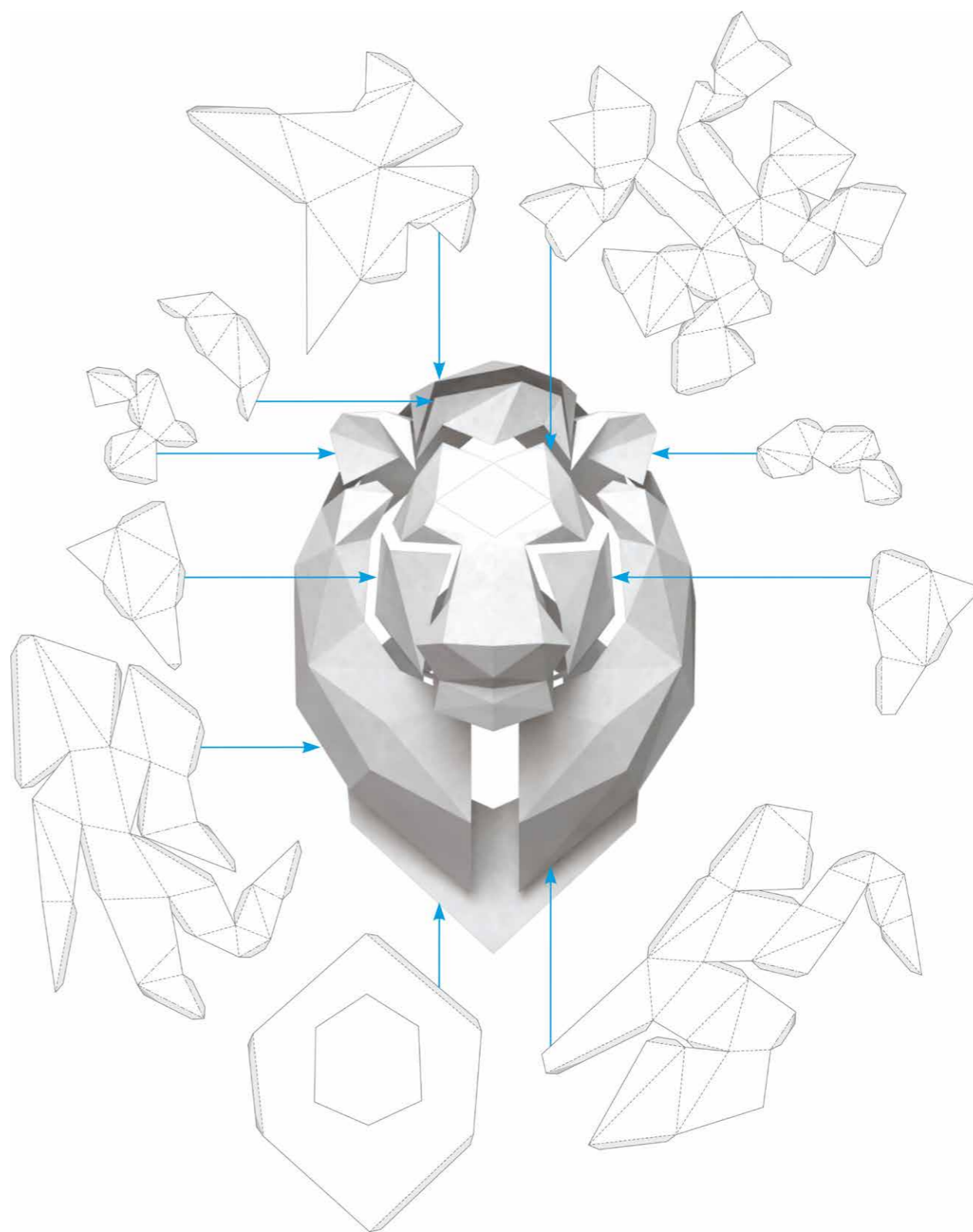



Author's note

Thank you for purchasing the files for making the head of a lion!

I have trying to do everything possible to make the process of gluing simple and straightforward, however, you will need about five hours on gluing the head of a lion.

For making a lion's head, it is desirable for you to have the skills of working with paper, but you can make a model, even if you have never done anything like this. In the first place, the result will depend on your attentiveness and exactitude.

I'll be glad if you send me a picture of how you made the lion's head out of paper!

You can see, how looks works, which have made other people, in the album on my page Polygonal Paper www.facebook.com/PolyPaper

Video tutorial: <https://youtu.be/Y63wporZrkE>



Natalya Bublik

✉ bubliknata@gmail.com

f <https://www.facebook.com/natalya.bublik>

📷 https://www.instagram.com/polygonal_paper/

Bē <https://www.behance.net/bublik>



You will need for work



A cutter and scissors.

You can use any cutter for paper. If you do not have a cutter, you can buy the cheapest one.



A ruler.

It will be better if you will use the metal ruler, because you may accidentally cut the ruler of a different material.



Glue.

Which does not deform the paper. Note that most of the PVA glues deform the paper. If you will make the model using this glue it will not bring to you any pleasure, because the PVA glue dries for a long time, and the paper gets wet from him, and then deformed. Lately I use a universal super glue Moment.



A surface for the cutting of sheets of paper.

You can use a piece of old linoleum, or a glass panel, or a clean cutting board.

A3

An A2 sheet of white cardboard for base.



Template.

A flat (unfolded 2d pattern), printed on paper weights 180-230 gr. / sq.m. In the archive which you downloaded, you can find the files for printing on A4, A3 and A1 paper sizes. Choose **one** of these formats, in all of it is the same size of pattern. Printing on A1 sheets of paper usually is cheaper, but not all printing houses can print a large format. Please, do not use office paper (80-90 gr./sq.m.). This paper is too thin.

If you want get a colored model, you can print the pattern on colored paper. Please do not paint the finished model, it can lead to deformation of the paper. You can find colored paper in stores for artists. It will be better for you to agree in advance with the printing house that they have agreed to print on your paper. You will get the best result if you use aquarelle paper. This paper has a light texture, thanks to this gluing places of the finished model is almost unnoticeable.

Work sequence

Cutting.

Cut out all the details of the flat pattern along the contour (indicated by the solid line). You will get the best result if you will cut the paper with a cutter by ruler. It is better not to use scissors, because they can make dents on the paper in the places of intersection of lines.

Folding.

Carefully score (but do not cut through) the paper along the dotted and dashed-dotted lines. This is necessary to make the folding of the paper in these places easier.

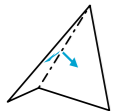

The dash-dotted lines denote folding of the paper to the outside (there are diverging arrows in this places);



The dotted lines appear in the places where the edges of the paper must be folded over to the inside (this movement is indicated by converging arrows).

Now you can fold all details along the lines.

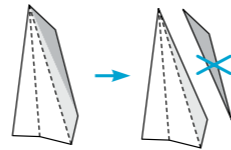

After folding cut out dark gray parts of flaps for gluing. Without them, it would be hard to fold the paper in these places, however, they will hamper to the gluing of paper.

Cutting of the base.

Find among cutted details the one that called the base. You can use it as a template - trace it on the cardboard and cut out. If you use A3 or A4 paper - there is only one half of the template. If you have A4 sheets, two parts of the template must first be stick together. If you use A1 colored paper, you can glue the base on the cardboard - so the base will have the same color as the model.

Gluing.

The side of the paper with lines is the inner side of the elephant head. The edges which should be glued together are denoted by the same numerals. For convenience, there are flaps on the unfolded 2d pattern (marked in gray). Start gluing together the edges from numbers «1», then «2», etc.



01 a Only for A4

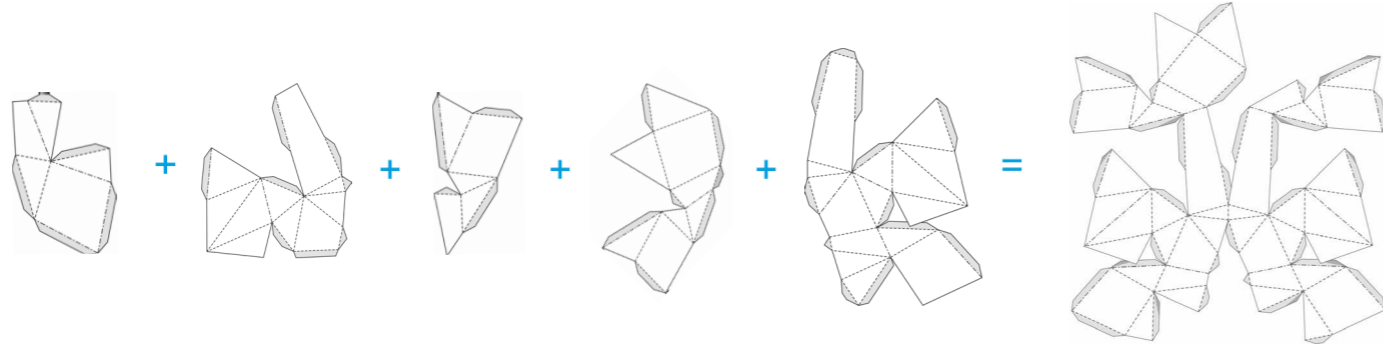

01 b Only for A3

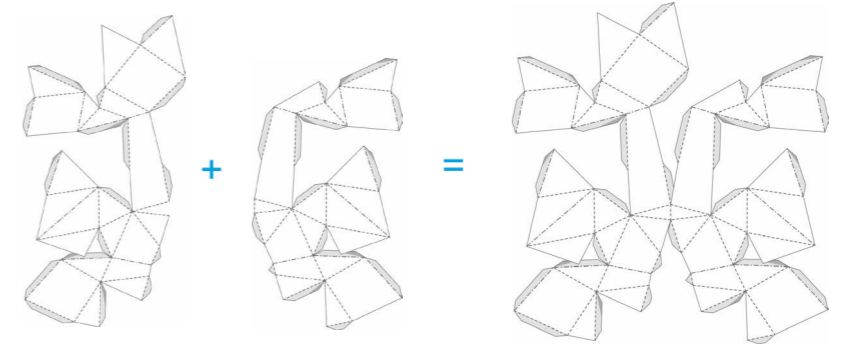

01

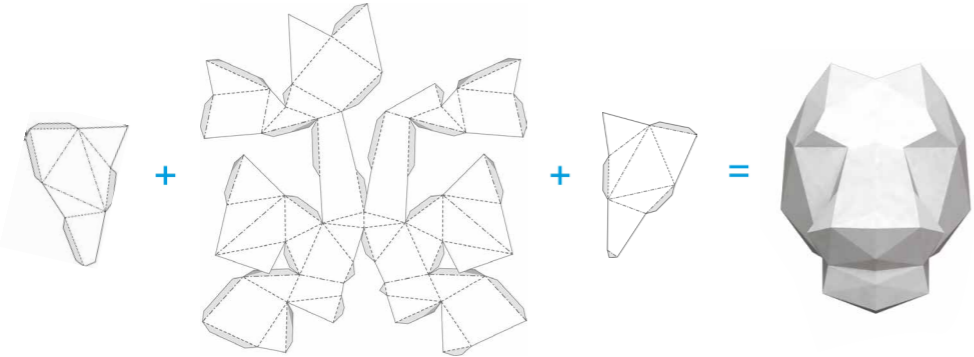

02

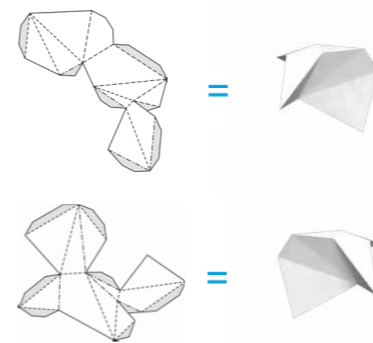

03 a Only for A4

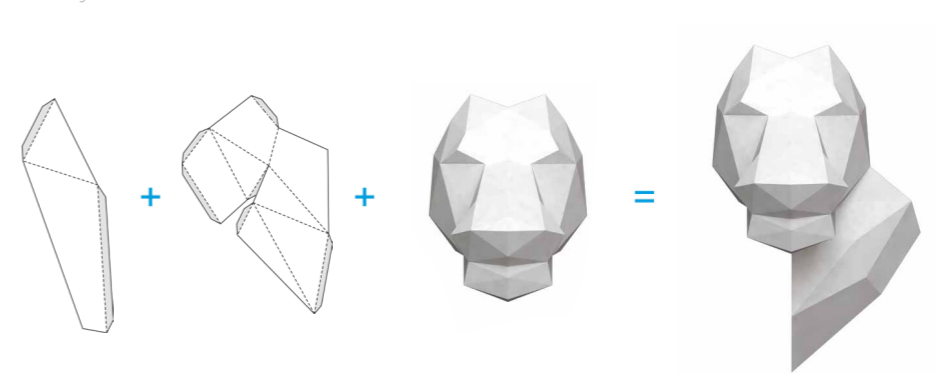

03 b Only for A3

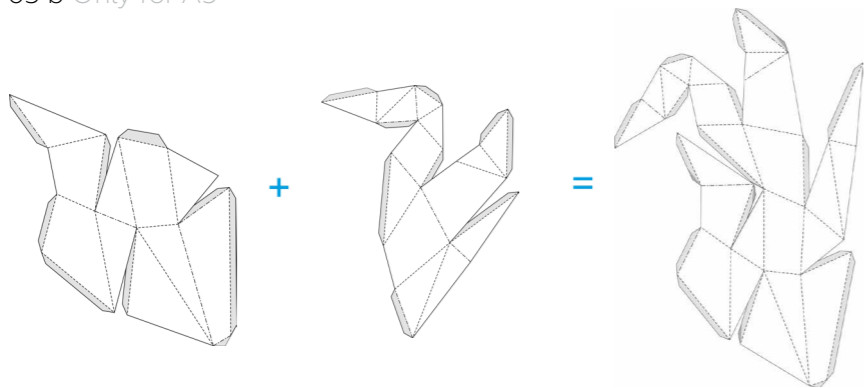

03 Only for A1 and A3

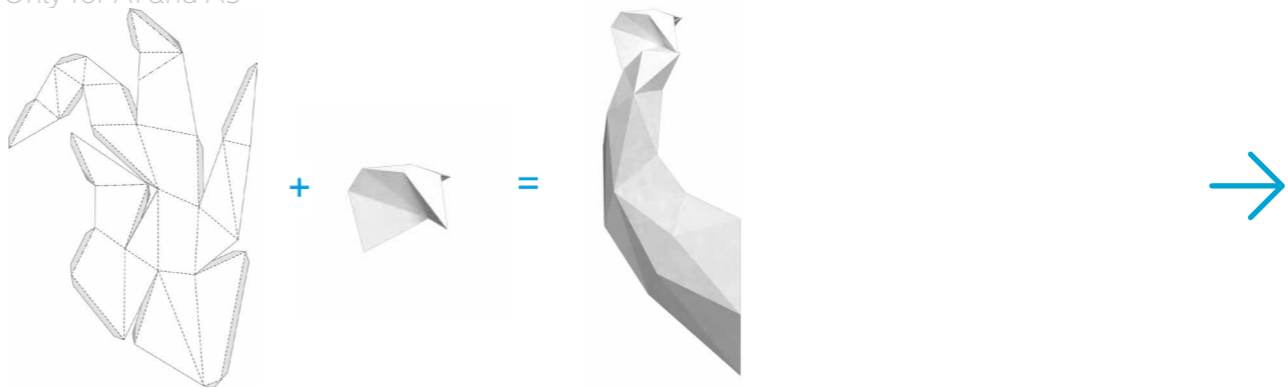

04 a Only for A4

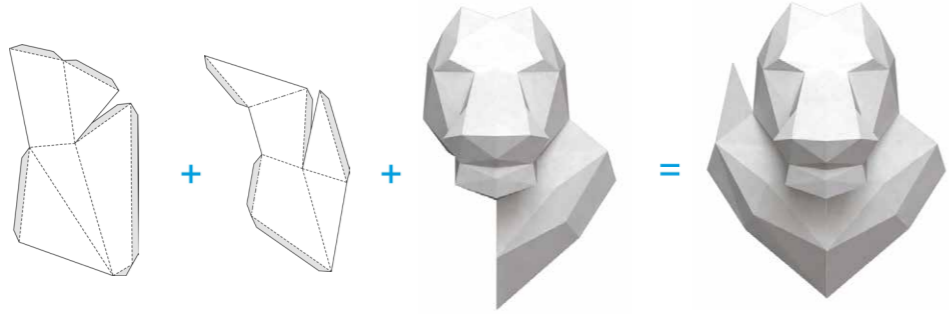

04 b Only for A3

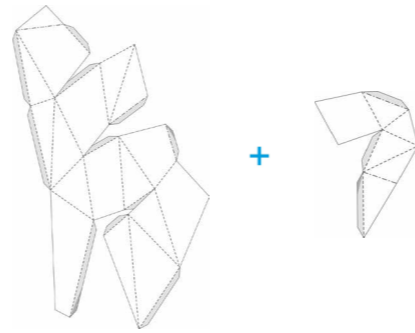

04 Only for A3 and A1

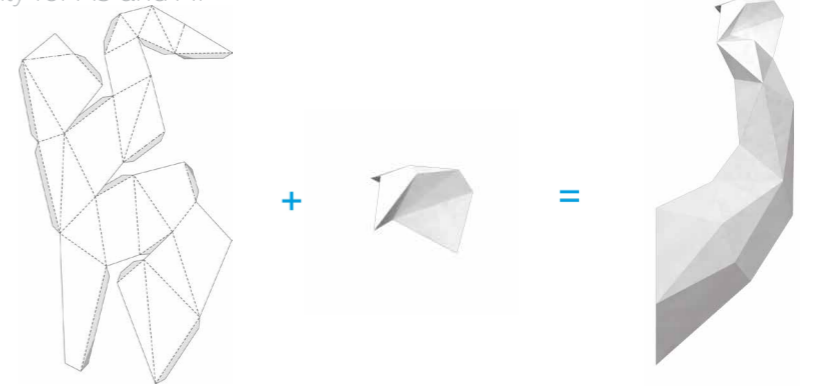

05 a Only for A4

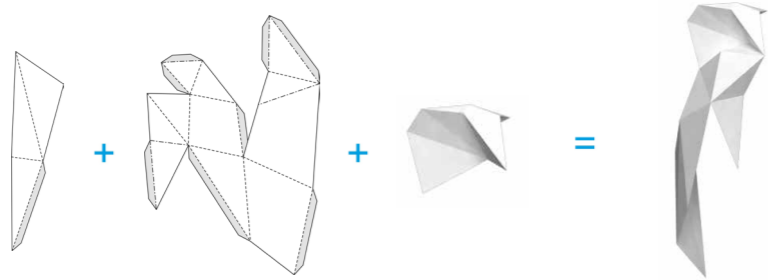

05 b Only for A4

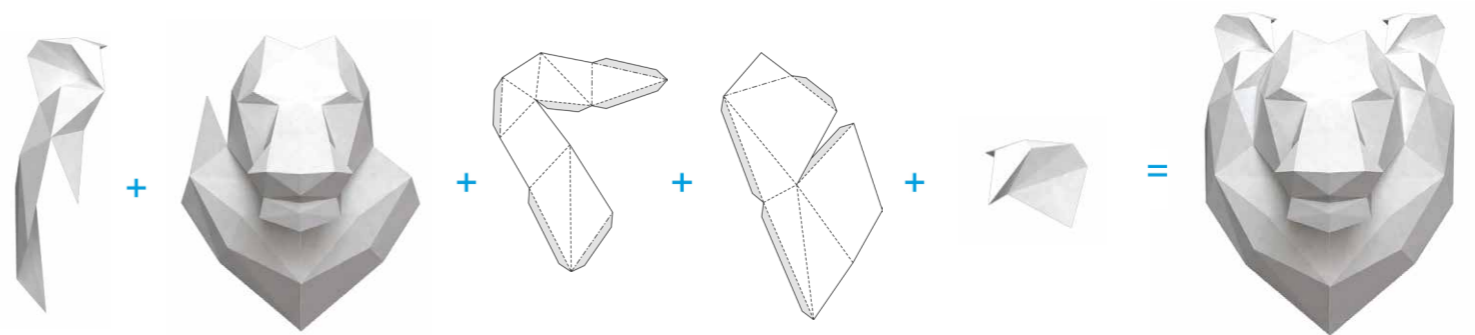

05 Only for A3 and A1

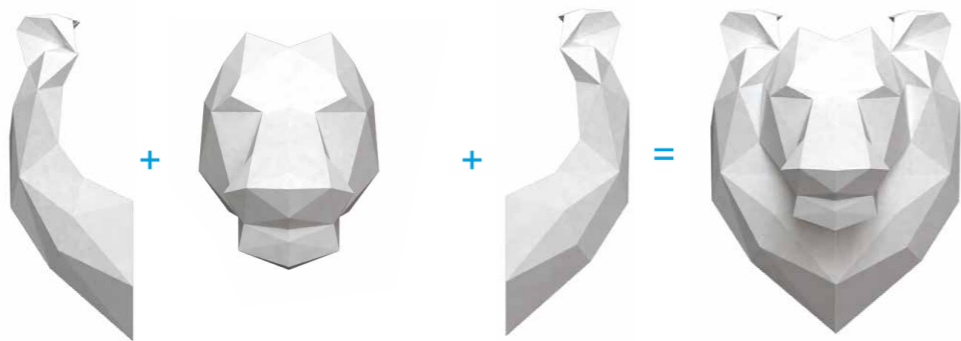

06

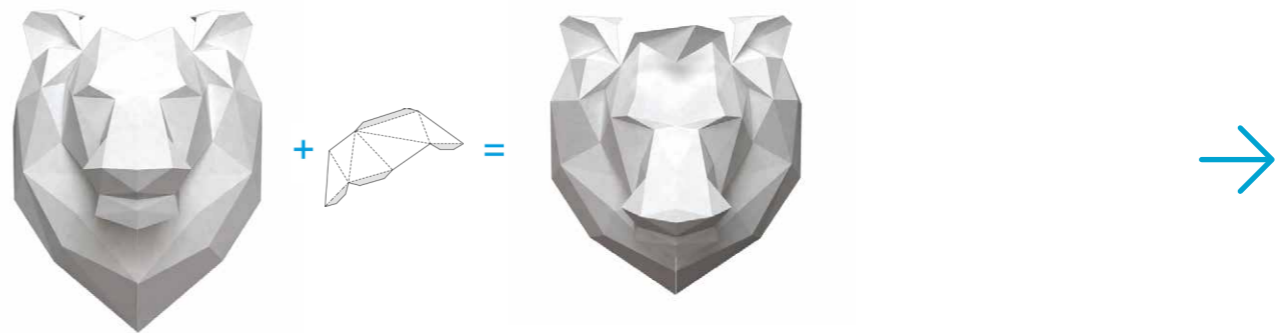

07 a Only for A4

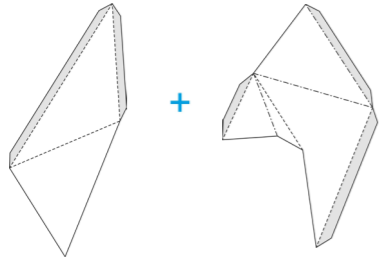

07 b Only for A4 and A3

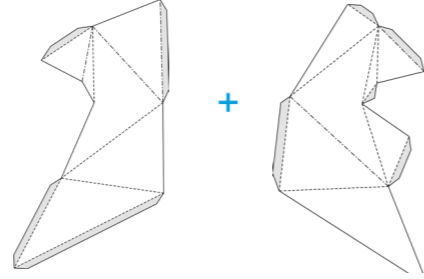

07

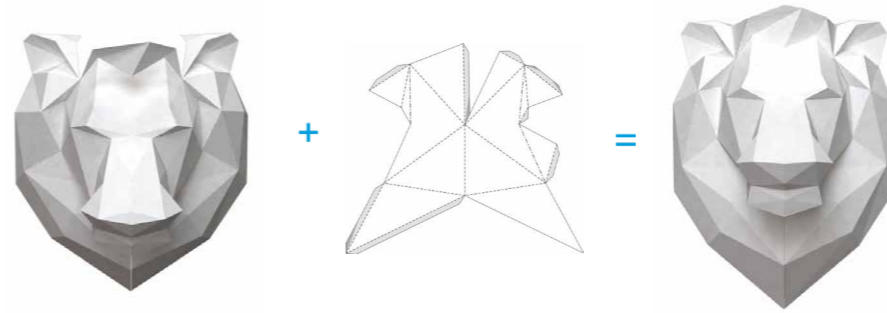

08 a Only for A4

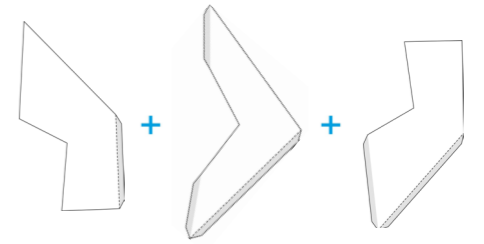

08

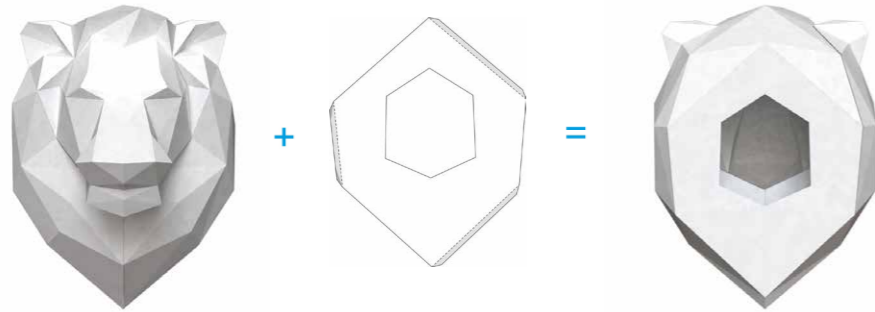

09

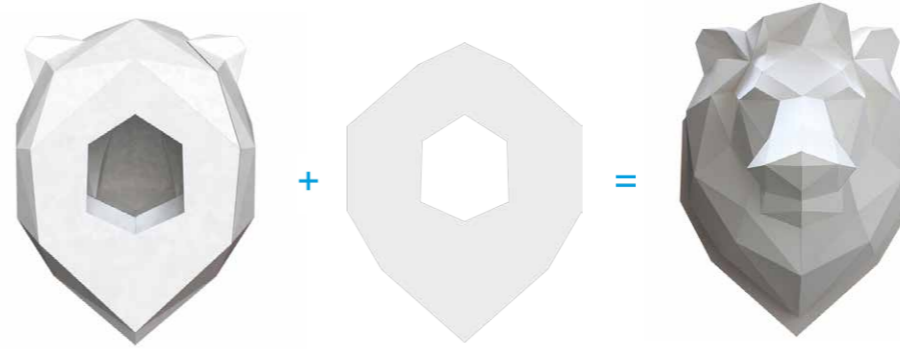



Thank you!